

|                       |      |     |     |     |     |     |     |     |     |     |     |     |     |
|-----------------------|------|-----|-----|-----|-----|-----|-----|-----|-----|-----|-----|-----|-----|
| BRACKET SPACING [in]  | 12   | 15  | 18  | 20  | 22  | 24  | 26  | 28  | 30  | 32  | 36  | 42  | 48  |
| LOAD CAPACITY [lb]    | 1212 | 970 | 808 | 727 | 661 | 606 | 560 | 519 | 485 | 454 | 404 | 346 | 303 |
| NO. OF SET SCR. PAIRS | 2    | 2   | 1   | 1   | 1   | 1   | 1   | 1   | 1   | 1   | 1   | 1   | 1   |

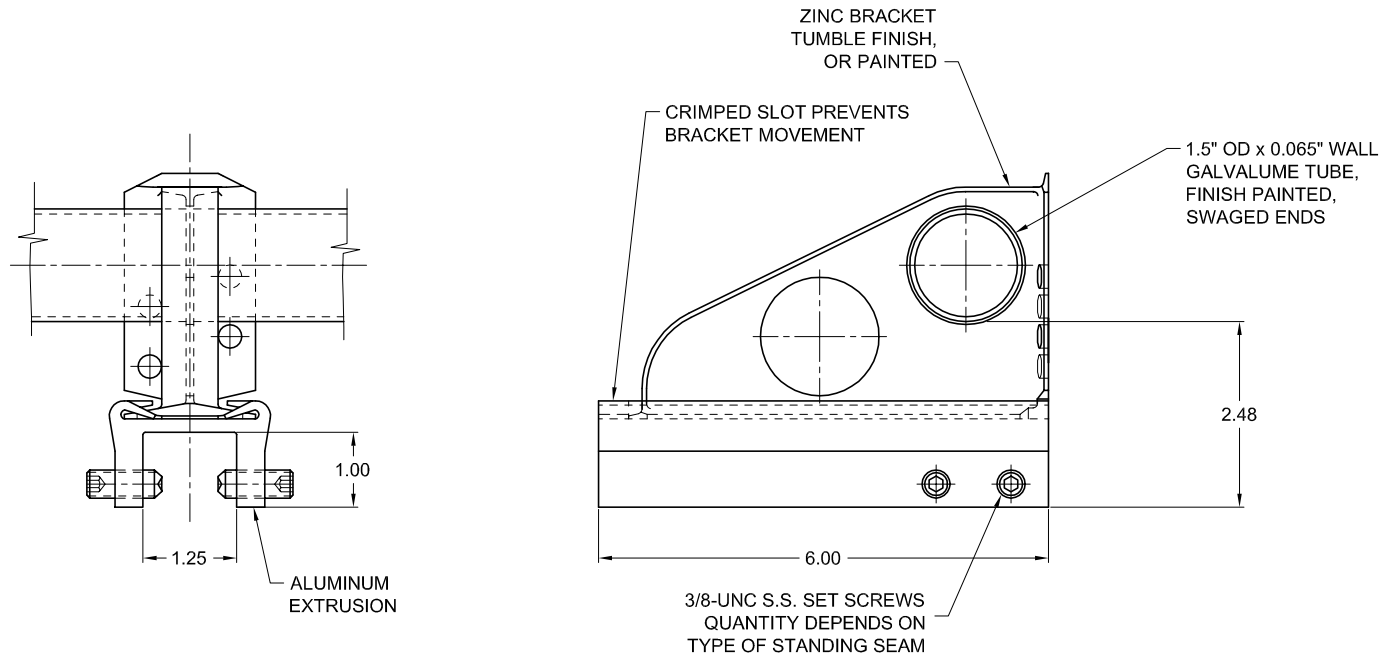

# SNOSTOP SMA-SS-1T

Roofers World Inc.

**“USA Patent No. 6,453,623 . Other Patents Pending”**

|   |                    |  |
|---|--------------------|--|
| DRWN BY<br>J. KRUPKA                                      | DATE<br>1 FEB 2002 | <b><i>SNOSTOP</i></b><br><br>SMA-SS-1T<br>SINGLE TUBE NON-PENETRATING SYSTEM |
| APPD BY   | TITLE              |  |
| SIGNATURE   | DATE               |  |
| STANDARD  | MATERIAL           |  |
| UNLESS OTHERWISE SPECIFIED, ALL DIMENSIONS ARE IN INCHES. |                    |  |
| DECIMALS<br>.X ±<br>.XX ±<br>.XXX ±                       | ANGLES<br>±        | HOLES<br>±   |
| SIZE<br>A   | DWG NO.<br>M0261   | ISSUE<br>A   |
| SCALE<br>NTS  | JOB REF. -         | SHEET<br>1/1   |

