

BRACKET SPACING [in]	12	15	18	20	22	24	26	28	30	32	36	42	48
LOAD CAPACITY [lb]	2424	1940	1616	1454	1322	1212	1120	1038	970	908	808	692	606
NO. OF SET SCR. PAIRS	3	3	2	2	2	2	2	2	2	1	1	1	1

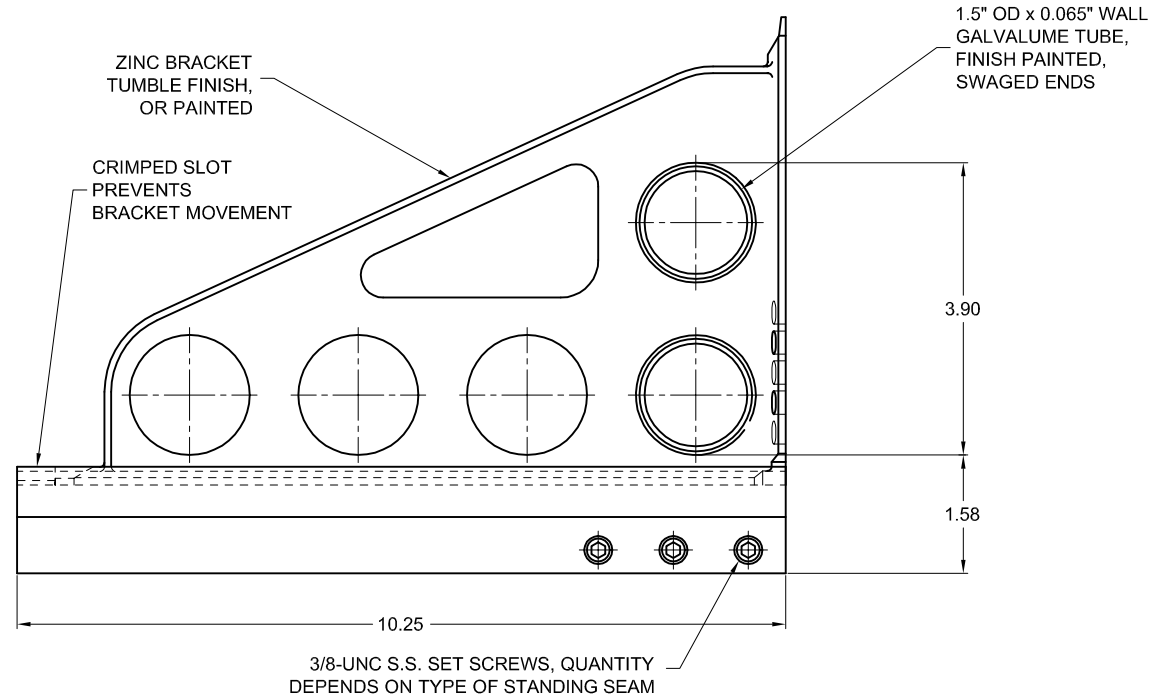
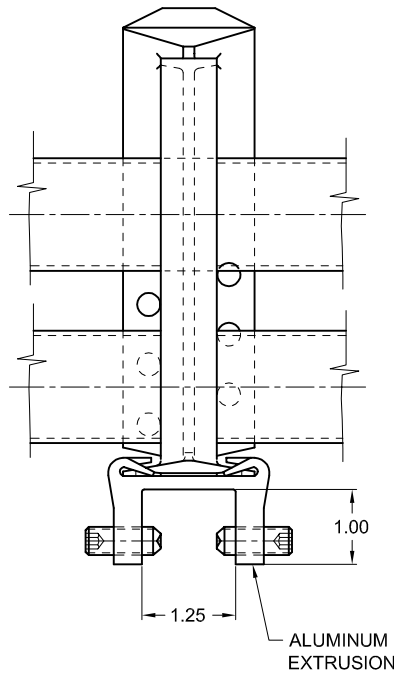

SNOSTOP LGA-SS-2T

Roofers World Inc.

"USA Patent No. 6,453,623 . Other Patents Pending"

DRWN BY J. KRUPKA	DATE 1 FEB 2002	SNOSTOP
APPD BY	TITLE	
SIGNATURE	DATE	
STANDARD	MATERIAL	
UNLESS OTHERWISE SPECIFIED, ALL DIMENSIONS ARE IN INCHES.		TITLE LGA-SS-2T DOUBLE TUBE NON-PENETRATING SYSTEM
DECIMALS .X ± .XX ± .XXX ±	ANGLES ±	HOLES ±
SIZE A	DWG NO. M0260	ISSUE A
SCALE NTS	JOB REF. -	SHEET 1/1

