

BRACKET SPACING [in]	12	15	18	20	22	24	26	28	30	32	36	42	48
LOAD CAPACITY [lb]	2350	1940	1616	1454	1322	1212	1120	1038	970	908	808	692	606
NO. OF SET SCR. PAIRS	3	3	2	1	2	2	2	2	2	2	1	1	1

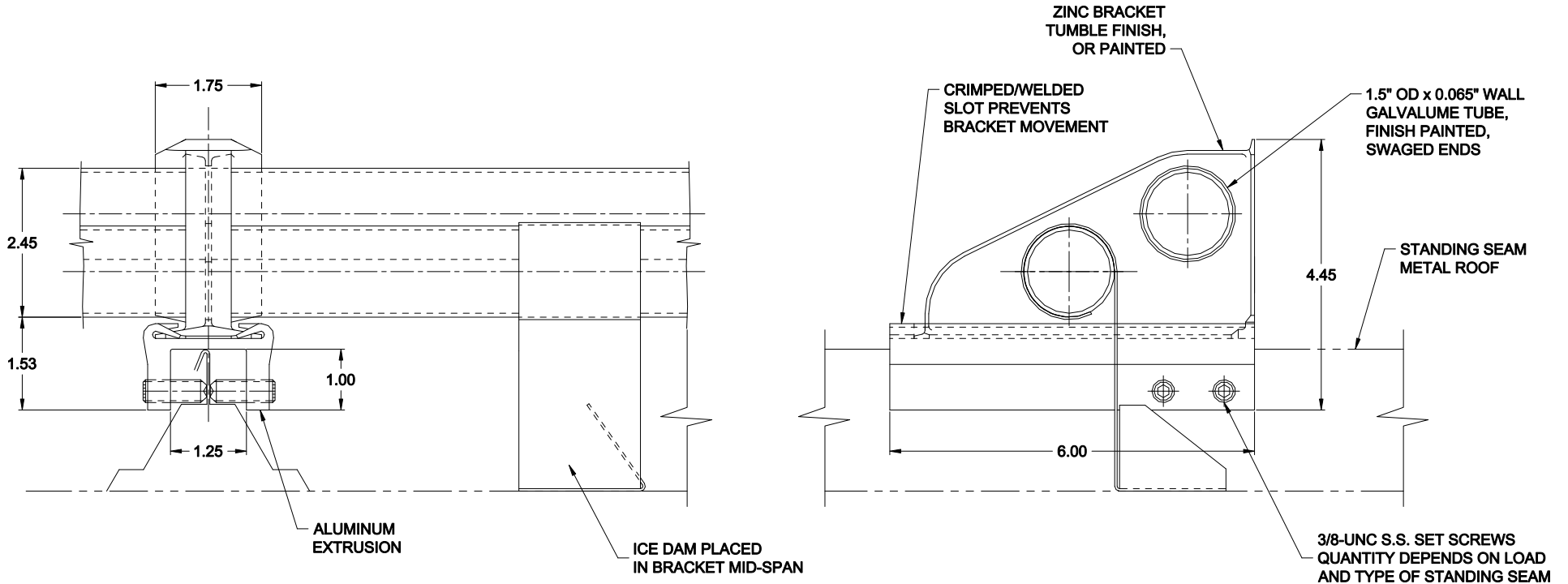

SNOSTOP SMA-SS-2T-ID

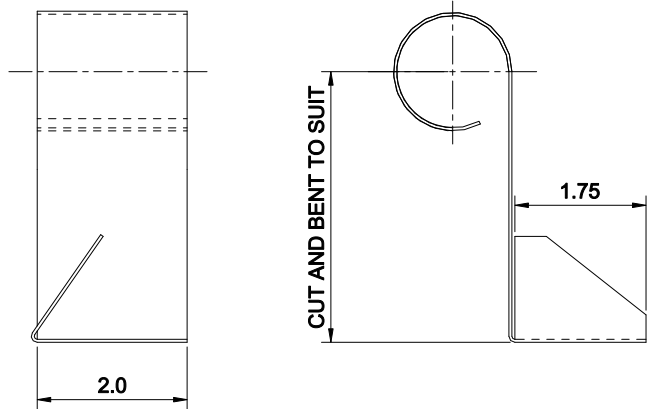

**ICE DAM
20GA GALVANIZED SHT. METAL**

THIS DRAWING IS THE PROPERTY OF ROOFERS ANNEX INC. AND IS SUBMITTED FOR CONSIDERATION ON THE UNDERSTANDING THAT THERE SHALL BE NO EXPLOITATION OF ANY INFORMATION HEREIN EXCEPT WITH THE SPECIFIC WRITTEN CONSENT OF ROOFERS ANNEX INC.

DRWN BY J. KRUPKA	DATE 27 JUNE 2005	
APPD BY	TITLE	
SIGNATURE	DATE	
STANDARD	MATERIAL	
UNLESS OTHERWISE SPECIFIED, ALL DIMENSIONS ARE IN INCHES.		
DECIMALS .X ± .XX ± .XXX ±	ANGLES ±	HOLES ±

<i>SNOSTOP</i> A DIVISION OF ROOFERS WORLD INC.	
TITLE SMA-SS-2T-ID DOUBLE TUBE NON-PENETRATING SYSTEM WITH ICE DAM	
SIZE A	DWG NO. M0265
SCALE NTS	JOB REF. -
ISSUE A	SHEET 1/1