

BRACKET SPACING [in]	12	15	18	20	22	24	26	28	30	32	36	42	48
LOAD CAPACITY [lb]	2350	1940	1616	1454	1322	1212	1120	1038	970	908	808	692	606
NO. OF SET SCR. PAIRS	3	3	2	1	2	2	2	2	2	2	1	1	1

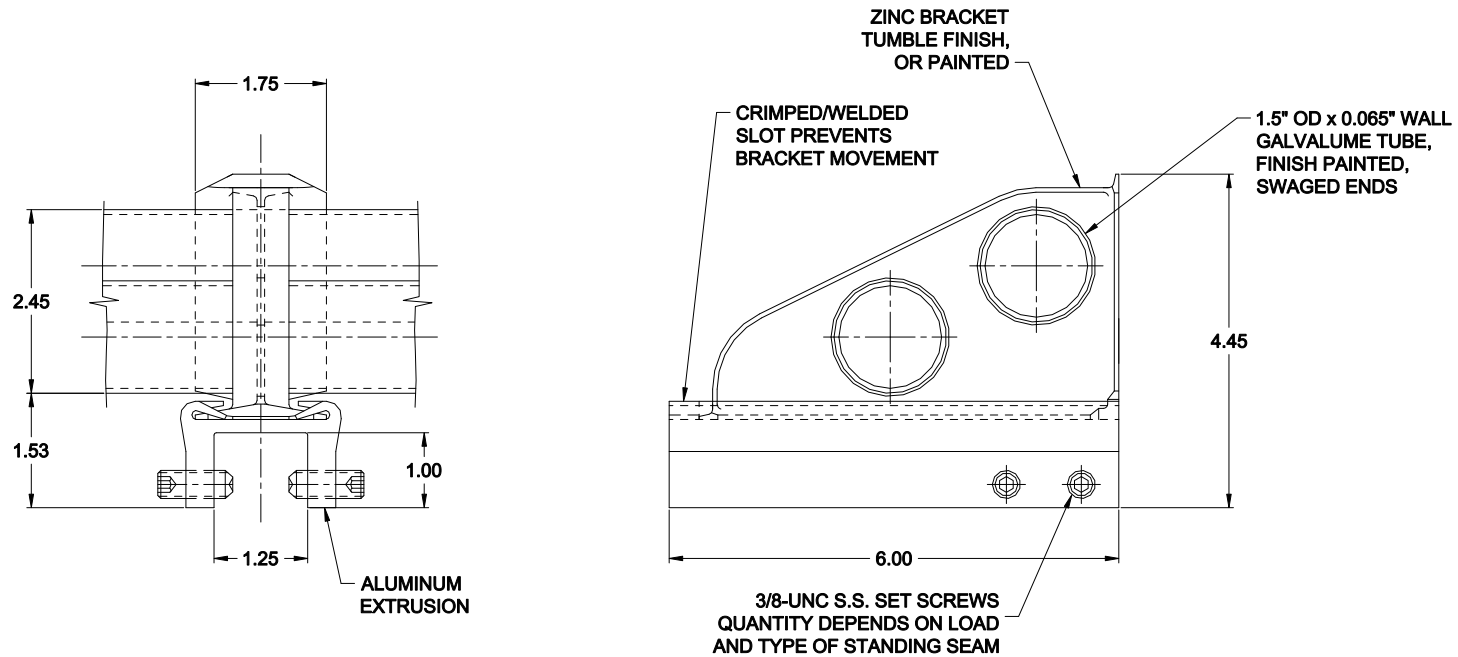

## SNOSTOP SMA-SS-2T

DRWN BY <b>J. KRUPKA</b>	DATE <b>30 OCT 2002</b>	<b><i>SNOSTOP</i></b> A DIVISION OF ROOFERS WORLD INC.  <b>SMA-SS-2T</b> <b>DOUBLE TUBE NON-PENETRATING SYSTEM</b>
APPD BY	TITLE	
SIGNATURE	DATE	
STANDARD	MATERIAL	
UNLESS OTHERWISE SPECIFIED, ALL DIMENSIONS ARE IN INCHES.		SIZE <b>A</b>
DECIMALS      ANGLES      HOLES .X            ±            ±            ± .XX          ±            ±            ± .XXX       ±            ±            ±		DWG NO. <b>M0264</b>
THIS DRAWING IS THE PROPERTY OF ROOFERS ANNEX INC. AND IS SUBMITTED FOR CONSIDERATION ON THE UNDERSTANDING THAT THERE SHALL BE NO EXPLOITATION OF ANY INFORMATION HEREIN EXCEPT WITH THE SPECIFIC WRITTEN CONSENT OF ROOFERS ANNEX INC.		SCALE <b>NTS</b>
		JOB REF. -
		SHEET <b>1/1</b>
		ISSUE <b>A</b>