

ROOF SPECIALTIES GAV-1A/-GAV-1C/GAV-1S GRAVITY AIR VENTS (Small Size Vents)



CALCULATING THE NUMBER OF GRAVITY AIR VENTS

INSIDE VENT DIAMETER	FREE VENTING AREA (SQ. INCHES)
3" (75 mm)	7.0686 (46 cm ²)
4" (102 mm)	12.5664 (81 cm ²)
5" (127 mm)	19.6350 (127 cm ²)
6" (152 mm)	28.2744 (182 cm ²)
7" (178 mm)	38.4846 (248 cm ²)
8" (203 mm)	50.2656 (324 cm ²)
9" (229 mm)	63.6174 (410 cm ²)
10" (254 mm)	78.5400 (507 cm ²)

144 Square inches (930 cm²) of free venting area is required to vent 300 square feet of roof area (1/300). A minimum of two vents are required to vent any individual roof area. Venting efficiency is increased in direct proportion to the number of vents used.

For example: Four vents each with 36 square inches (232 cm²) of free venting area on a 300 square foot (28 m²) roof is preferable to using two vents, each with 72 square inches (464 cm²) of free venting area. Increasing the number of vents, while maintain the required total amount of free venting area by decreasing the size of the individual vents allows air to be drawn from the corners of the roof, thereby increasing overall venting efficiency, and avoiding condensation formation.

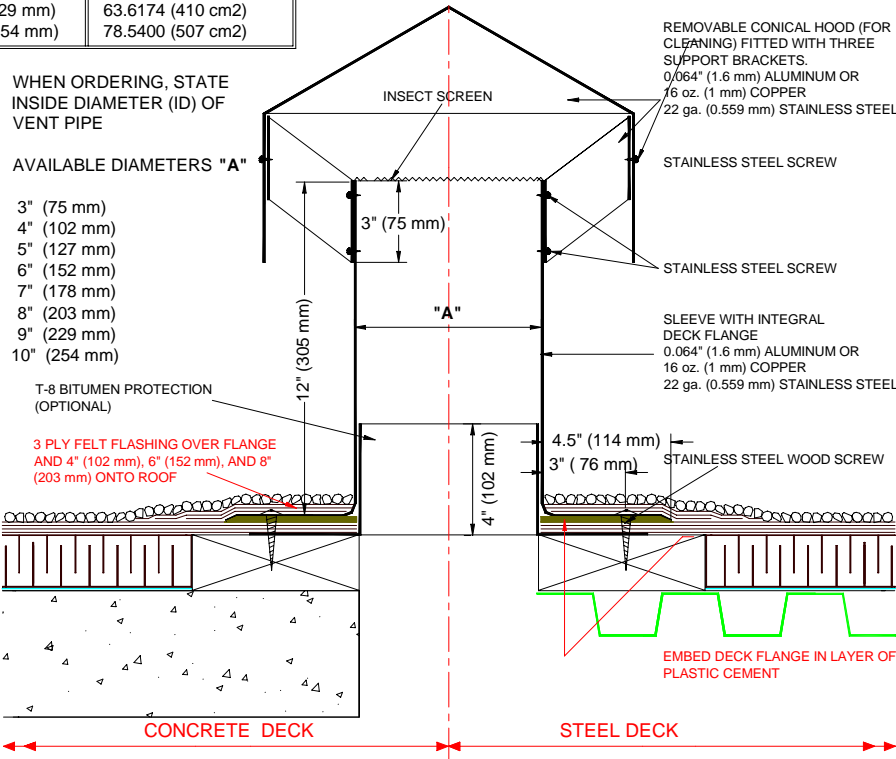

GAV-1A, GAV-1C, GAV-1SS GRAVITY AIR VENTS (Small Size Vents)

INSTALLATION

"Installation Instructions" are provided with every Thaler product. Essentially, Thaler Gravity Air Vents are installed at recommended locations by first installing the roof membrane, then screwing the deck flange through to a wood blocking (by others) located under the membrane, and as follows:

BUR: Cut roof membrane back 1" (25 mm) from hole in deck before installing vent and fill space with plastic cement to prevent bitumen drippage at elevated roof temperatures. Set vent deck flange in layer of plastic cement and flash in with 3 overlapping layers of felt flashing.

ModBit: Cut roof membrane back 1" (25 mm) from hole in deck before installing vent and fill space with plastic cement to prevent bitumen drippage at elevated roof temperatures. Torch membrane until bitumen is fluid and set vent deck flange into fluid. Flash in flange with two overlapping layers of ModBit and seal with asphalt sealer.

Single Ply: Set vent deck flange in layer of membrane adhesive and extend single ply up vent sleeve to highest elevation possible and clamp membrane to sleeve. Note: for PVC membrane, specify PVC coated deck flange by adding suffix P to end of model number e.g. GAV-1A-P; weld roofing to deck flange using PVC torch. Note: for EPDM, coat deck flange on site with contact cement before torching membrane to deck flange.

Precautions: If coating deck flange with a bituminous paint on site, allow 24 hours for drying before applying roof membrane.

Ordering and Availability: Specify flashing material required by adding appropriate suffix to model number e.g. GAV-1A, for aluminum, etc. Available throughout North America. Contact Thaler for list of distributors and current cost information. Most products are readily available from stock.

DESCRIPTION

Thaler GAV-1 Gravity Air Vents consist of a metal sleeve with integral deck flange, removable conical hood fitted with a three support brackets, and insect screen. Available in aluminum (GAV-1A), copper (GAV-1C), or stainless steel (GAV-1S).

Diameter: From 3" (76 mm) and 10" (254 mm).
NBC (National Building Code) Requirement: For "Low Slope Roofs" where insulation is placed below the roof sheathing in roofs having a slope of less than 1 in 6, or in roofs that are constructed with roof joists, the unobstructed vent area shall not be less than 1/150 of the insulated ceiling area. Vents shall be uniformly distributed to ventilate each roof space.

Spacing: For any given roof, Thaler recommends a minimum 3" (76 mm) vent be located at each corner of the roof and a minimum of one vent in the middle of the roof. Venting efficiency is directly proportional to the number of vents employed e.g. 4 vents, each with 36 sq. in. (26 cm²) on a 300 sq. ft. (28 m²) roof is preferable to using 2 vents, each with a 72 sq. in. (54 cm²) of free venting area. Increasing the number of vents allows air to be drawn from the corners of the roof area thereby increasing overall venting efficiency while preventing the formation of condensation. Note: A minimum of two vents is required to vent any individual roof area.

Options: T-8 bitumen protection.

RECOMMENDED USE

Suitable for all flat/low slope roofs for venting of plenum spaces. Primarily designed for built up roofing (BUR) and modified bitumen roofing, or single ply roofs providing the deck flange has been treated for proper weld with the single ply. e.g. PVC coated deck flange for PVC membrane or contact cement coated deck flange for EPDM membrane. Consult Thaler representative for other single plys. See Thaler GAV-2 Gravity Air Vents for larger capacity vents.

WARRANTY

20 year warranty against defects in materials and/or manufacture when installed in accordance with Thaler "Installation Instructions". Copy of Warranty Certificate available upon request.

MAINTENANCE

No maintenance required (maintenance free).

SPECIFICATION (Short Form)

Gravity air vents: Thaler [GAV-1A] [GAV-1C] [GAV-1SS] standard 12" (305 mm) high, [3" (76 mm)] [4" (102 mm)] diameter gravity air vent consisting of [.064" (1.6 mm) mill finish 1100-O1 alloy aluminum] [.021 (0.53 mm) 16 oz. copper] [.018" (0.46 mm) type 304 stainless steel] with integral deck flange, removable conical hood fitted with three support brackets, and insect screen. [T-8 bitumen protection sleeve] [bituminous painted deck flange] [PVC coated deck flange] [plain deck flange]; manufactured by Thaler Metal Industries, 1-800-387-7217 (Mississauga, Ontario, Canada) or 1-800-576-1200 (Niagara Falls, NY), installed as per manufacturer's written instructions. Provide 20 year warranty against defects in materials and/or manufacture.

ROOF SPECIALTIES GAV-1A/-GAV-1C/GAV-1S GRAVITY AIR VENTS (Small Size Vents)



CALCULATING THE NUMBER OF GRAVITY AIR VENTS

INSIDE VENT DIAMETER	FREE VENTING AREA (SQ. INCHES)
3" (75 mm)	7.0686 (46 cm ²)
4" (102 mm)	12.5664 (81 cm ²)
5" (127 mm)	19.6350 (127 cm ²)
6" (152 mm)	28.2744 (182 cm ²)
7" (178 mm)	38.4846 (248 cm ²)
8" (203 mm)	50.2656 (324 cm ²)
9" (229 mm)	63.6174 (410 cm ²)
10" (254 mm)	78.5400 (507 cm ²)

144 Square inches (930 cm²) of free venting area is required to vent 300 square feet of roof area (1/300). A minimum of two vents are required to vent any individual roof area. Venting efficiency is increased in direct proportion to the number of vents used.

For example: Four vents each with 36 square inches (232 cm²) of free venting area on a 300 square foot (28 m²) roof is preferable to using two vents, each with 72 square inches (464 cm²) of free venting area. Increasing the number of vents, while maintain the required total amount of free venting area by decreasing the size of the individual vents allows air to be drawn from the corners of the roof, thereby increasing overall venting efficiency, and avoiding condensation formation.

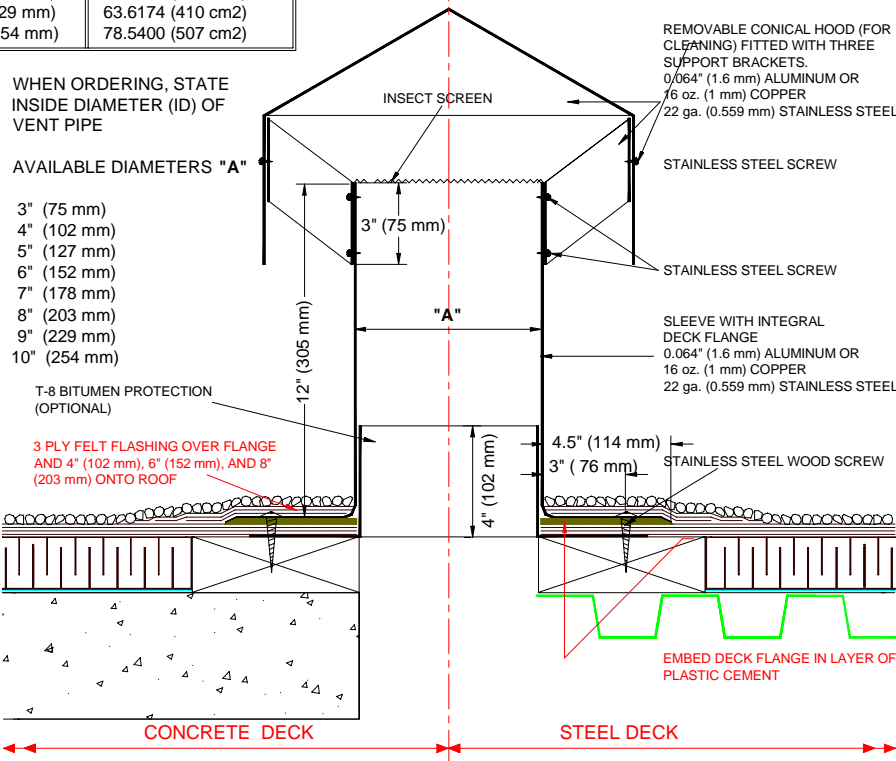

GAV-1A, GAV-1C, GAV-1SS GRAVITY AIR VENTS (Small Size Vents)

INSTALLATION

"Installation Instructions" are provided with every Thaler product. Essentially, Thaler Gravity Air Vents are installed at recommended locations by first installing the roof membrane, then screwing the deck flange through to a wood blocking (by others) located under the membrane, and as follows:

BUR: Cut roof membrane back 1" (25 mm) from hole in deck before installing vent and fill space with plastic cement to prevent bitumen drippage at elevated roof temperatures. Set vent deck flange in layer of plastic cement and flash in with 3 overlapping layers of felt flashing.

ModBit: Cut roof membrane back 1" (25 mm) from hole in deck before installing vent and fill space with plastic cement to prevent bitumen drippage at elevated roof temperatures. Torch membrane until bitumen is fluid and set vent deck flange into fluid. Flash in flange with two overlapping layers of ModBit and seal with asphalt sealer.

Single Ply: Set vent deck flange in layer of membrane adhesive and extend single ply up vent sleeve to highest elevation possible and clamp membrane to sleeve. Note: for PVC membrane, specify PVC coated deck flange by adding suffix P to end of model number e.g. GAV-1A-P; weld roofing to deck flange using PVC torch. Note: for EPDM, coat deck flange on site with contact cement before torching membrane to deck flange.

Precautions: If coating deck flange with a bituminous paint on site, allow 24 hours for drying before applying roof membrane.

Ordering and Availability: Specify flashing material required by adding appropriate suffix to model number e.g. GAV-1A, for aluminum, etc. Available throughout North America. Contact Thaler for list of distributors and current cost information. Most products are readily available from stock.

DESCRIPTION

Thaler GAV-1 Gravity Air Vents consist of a metal sleeve with integral deck flange, removable conical hood fitted with a three support brackets, and insect screen. Available in aluminum (GAV-1A), copper (GAV-1C), or stainless steel (GAV-1S).

Diameter: From 3" (76 mm) and 10" (254 mm).
NBC (National Building Code) Requirement: For "Low Slope Roofs" where insulation is placed below the roof sheathing in roofs having a slope of less than 1 in 6, or in roofs that are constructed with roof joists, the unobstructed vent area shall not be less than 1/150 of the insulated ceiling area. Vents shall be uniformly distributed to ventilate each roof space.

Spacing: For any given roof, Thaler recommends a minimum 3" (76 mm) vent be located at each corner of the roof and a minimum of one vent in the middle of the roof. Venting efficiency is directly proportional to the number of vents employed e.g. 4 vents, each with 36 sq. in. (26 cm²) on a 300 sq. ft. (28 m²) roof is preferable to using 2 vents, each with a 72 sq. in. (54 cm²) of free venting area. Increasing the number of vents allows air to be drawn from the corners of the roof area thereby increasing overall venting efficiency while preventing the formation of condensation. Note: A minimum of two vents is required to vent any individual roof area.

Options: T-8 bitumen protection.

RECOMMENDED USE

Suitable for all flat/low slope roofs for venting of plenum spaces. Primarily designed for built up roofing (BUR) and modified bitumen roofing, or single ply roofs providing the deck flange has been treated for proper weld with the single ply. e.g. PVC coated deck flange for PVC membrane or contact cement coated deck flange for EPDM membrane. Consult Thaler representative for other single plys. See Thaler GAV-2 Gravity Air Vents for larger capacity vents.

WARRANTY

20 year warranty against defects in materials and/or manufacture when installed in accordance with Thaler "Installation Instructions". Copy of Warranty Certificate available upon request.

MAINTENANCE

No maintenance required (maintenance free).

SPECIFICATION (Short Form)

Gravity air vents: Thaler [GAV-1A] [GAV-1C][GAV-1SS] standard 12" (305 mm) high, [3" (76 mm)][4" (102 mm)] diameter gravity air vent consisting of [.064" (1.6 mm) mill finish 1100-O1 alloy aluminum] [.021 (0.53 mm) 16 oz. copper] [.018" (0.46 mm) type 304 stainless steel] with integral deck flange, removable conical hood fitted with three support brackets, and insect screen. [T-8 bitumen protection sleeve] [bituminous painted deck flange][PVC coated deck flange][plain deck flange]; manufactured by Thaler Metal Industries, 1-800-387-7217 (Mississauga, Ontario, Canada) or 1-800-576-1200 (Niagara Falls, NY), installed as per manufacturer's written instructions. Provide 20 year warranty against defects in materials and/or manufacture.

ROOF SPECIALTIES GAV-2A/-GAV-2C/GAV-2SS GRAVITY AIR VENTS (Large Size Vents)



CALCULATING THE NUMBER OF GRAVITY AIR VENTS

144 Square inches (930 cm²) of free venting area is required to vent 300 square feet of roof area (1/300). A minimum of two vents are required to vent any individual roof area. Venting efficiency is increased in direct proportion to the number of vents used.

For example: Four vents each with 36 square inches (232 cm²) of free venting area on a 300 square foot (28 m²) roof is preferable to using two vents, each with 72 square inches (464 cm²) of free venting area. Increasing the number of vents, while maintaining the required total amount of free venting area by decreasing the size of the individual vents allows air to be drawn from the corners of the roof, thereby increasing overall venting efficiency, and avoiding condensation formation.

A	B	C	D	Area Sq. Inches
12"DIA. (305mm)	24" (610mm)	14" (356mm)	6"-1/2" (165mm)	113.098 SQ.INCHES 730 (cm ²)
14"DIA. (356mm)	28" (711mm)	14" (356mm)	7" (178mm)	153.938 SQ.INCHES 993 (cm ²)
16"DIA. (406mm)	32" (813mm)	15" (381mm)	7-1/2" (191mm)	201.062 SQ.INCHES 1297 (cm ²)
18"DIA. (457mm)	36" (914mm)	16" (356mm)	8" (203mm)	254.470 SQ.INCHES 1641 (cm ²)
20"DIA. (508mm)	40" (1016mm)	18" (467mm)	8-3/4" (222mm)	314.160 SQ.INCHES 2026 (cm ²)

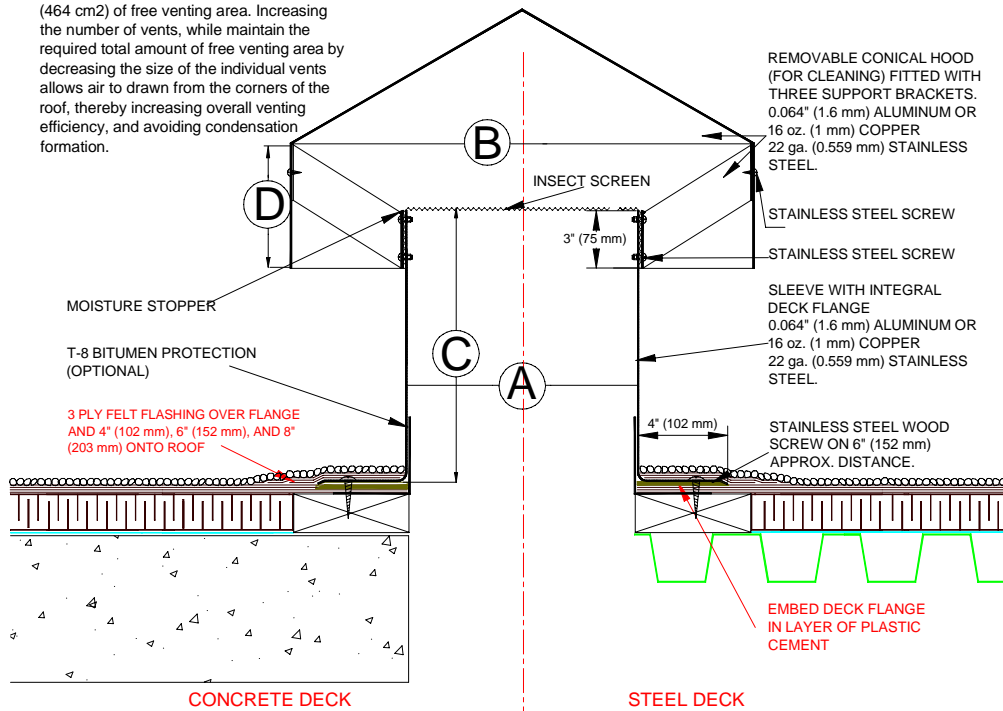

GAV-2A, GAV-2C, GAV-2SS GRAVITY AIR VENTS (Large Size Vents)

INSTALLATION

"Installation Instructions" are provided with every Thaler product. Essentially, Thaler Gravity Air Vents are installed at recommended locations by first installing the roof membrane, then screwing the deck flange through to a wood blocking (by others) located under the membrane, and as follows:

BUR: Cut roof membrane back 1" (25 mm) from hole in deck before installing vent and fill space with plastic cement to prevent bitumen drippage at elevated roof temperatures. Set vent deck flange in layer of plastic cement and flash in with 3 overlapping layers of felt flashing.

ModBit: Cut roof membrane back 1" (25 mm) from hole in deck before installing vent and fill space with plastic cement to prevent bitumen drippage at elevated roof temperatures. Torch membrane until bitumen is fluid and set vent deck flange into fluid. Flash in flange with two overlapping layers of ModBit and seal with asphalt sealer.

Single Ply: Set vent deck flange in layer of membrane adhesive and extend single ply up vent sleeve to highest elevation possible and clamp membrane to sleeve. Note: for PVC membrane, specify PVC coated deck flange by adding suffix P to end of model number e.g. GAV-1A-P; weld roofing to deck flange using PVC torch. Note: for EPDM, coat deck flange on site with contact cement before torching membrane to deck flange.

Precautions: If coating deck flange with a bituminous paint on site, allow 24 hours for drying before applying roof membrane.

Ordering and Availability: Specify flashing material required by adding appropriate suffix to model number e.g. GAV-1A, for aluminum, etc. Available throughout North America. Contact Thaler for list of distributors and current cost information. Most products are readily available from stock.

DESCRIPTION

Thaler GAV-2 Gravity Air Vents consist of a metal sleeve with integral deck flange, removable conical hood fitted with a three support brackets, and insect screen. Available in aluminum (GAV-2A), copper (GAV-2C), or stainless steel (GAV-2SS).

Diameter: From 12" (305 mm) to 20" (508 mm).

NBC (National Building Code) Requirement: For "Low Slope Roofs" where insulation is placed below the roof sheathing in roofs having a slope of less than 1 in 6, or in roofs that are constructed with roof joists, the unobstructed vent area shall not be less than 1/150 of the insulated ceiling area. Vents shall be uniformly distributed to ventilate each roof space.

Spacing: For any given roof, Thaler recommends a minimum 3" (76 mm) vent be located at each corner of the roof and a minimum of one vent in the middle of the roof. Venting efficiency is directly proportional to the number of vents employed e.g. 4 vents, each with 36 sq. in. (26 cm²) on a 300 sq. ft. (28 m²) roof is preferable to using 2 vents, each with a 72 sq. in. (54 cm²) of free venting area. Increasing the number of vents allows air to be drawn from the corners of the roof area thereby increasing overall venting efficiency while preventing the formation of condensation. Note: A minimum of two vents is required to vent any individual roof area.

Options: T-8 bitumen protection.

RECOMMENDED USE

Suitable for all flat/low slope roofs for venting of plenum spaces. Primarily designed for built up roofing (BUR) and modified bitumen roofing, or single ply roofs providing the deck flange has been treated for proper weld with the single ply. e.g. PVC coated deck flange for PVC membrane or contact cement coated deck flange for EPDM membrane. Consult Thaler representative for other single plys. See Thaler GAV-2 Gravity Air Vents for larger capacity vents.

WARRANTY

20 year warranty against defects in materials and/or manufacture when installed in accordance with Thaler "Installation Instructions". Copy of Warranty Certificate available upon request.

MAINTENANCE

No maintenance required (maintenance free).

SPECIFICATION (Short Form)

Gravity air vents: Thaler [GAV-1A] [GAV-1C][GAV-1SS] standard 12" (305 mm) high, [12" (305 mm)][20" (508 mm)] diameter gravity air vent consisting of [.064" (1.6 mm) mill finish 1100-OT alloy aluminum] [.021 (0.53 mm) 16 oz. copper] [.018" (0.46 mm) type 304 stainless steel] with integral deck flange, removable conical hood fitted with three support brackets, and insect screen. [T-8 bitumen protection sleeve] [bituminous painted deck flange][PVC coated deck flange][plain deck flange]; manufactured by Thaler Metal Industries, 1-800-387-7217 (Mississauga, Ontario, Canada) or 1-800-576-1200 (Niagara Falls, NY), installed as per manufacturer's written instructions. Provide 20 year warranty against defects in materials and/or manufacture.

ROOF SPECIALTIES GAV-3A/-GAV-3C/GAV-3SS GRAVITY AIR VENTS (Small Size Vents-Slope Roofs)

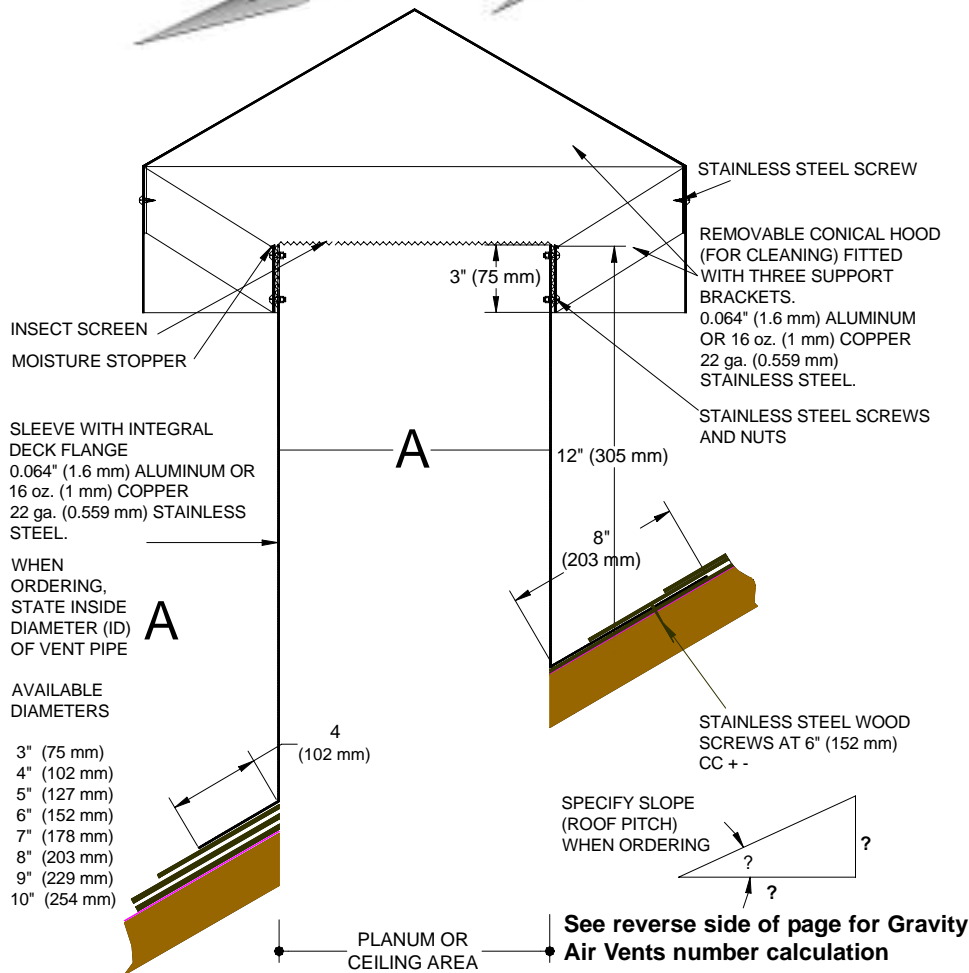
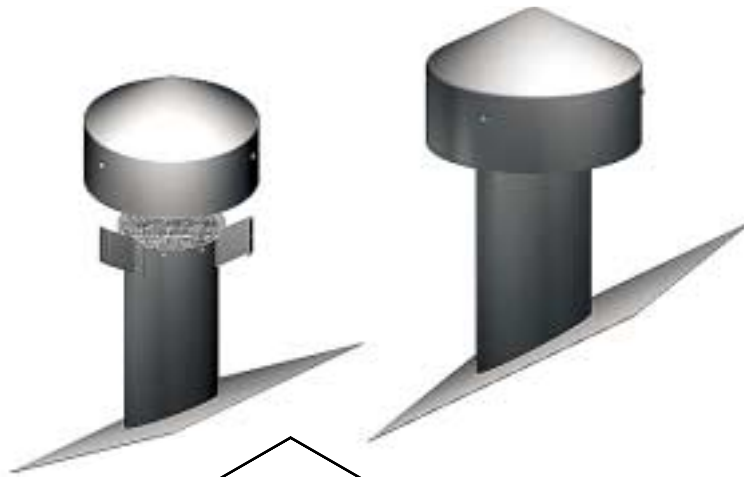

GAV-3A, GAV-3C, GAV-3SS GRAVITY AIR VENTS (Small Size Vents For Sloped Roofs)

INSTALLATION

"Installation Instructions" are provided with every Thaler product. Essentially, Thaler Gravity Air Vents are installed at recommended locations by first installing the roof membrane, then screwing the deck flange through to a wood blocking (by others) located under the membrane, and as follows:

BUR: Cut roof membrane back 1" (25 mm) from hole in deck before installing vent and fill space with plastic cement to prevent bitumen drippage at elevated roof temperatures. Set vent deck flange in layer of plastic cement and flash in with 3 overlapping layers of felt flashing.

ModBit: Cut roof membrane back 1" (25 mm) from hole in deck before installing vent and fill space with plastic cement to prevent bitumen drippage at elevated roof temperatures. Torch membrane until bitumen is fluid and set vent deck flange into fluid. Flash in flange with two overlapping layers of ModBit and seal with asphalt sealer.

Single Ply: Set vent deck flange in layer of membrane adhesive and extend single ply up vent sleeve to highest elevation possible and clamp membrane to sleeve. Note: for PVC membrane, specify PVC coated deck flange by adding suffix P to end of model number e.g. GAV-1A-P; weld roofing to deck flange using PVC torch. Note: for EPDM, coat deck flange on site with contact cement before torching membrane to deck flange.

Precautions: If coating deck flange with a bituminous paint on site, allow 24 hours for drying before applying roof membrane.

Ordering and Availability: Specify flashing material required by adding appropriate suffix to model number e.g. GAV-1A, for aluminum, etc. Available throughout North America. Contact Thaler for list of distributors and current cost information. Most products are readily available from stock.

DESCRIPTION

Thaler GAV-3 Gravity Air Vents for sloped roofs consist of a metal sleeve with integral deck flange, removable conical hood fitted to sleeve with a three support brackets, and insect screen. Available in aluminum (GAV-3A), copper (GAV-3C), or stainless steel (GAV-3SS).

Diameter: From 3" (76 mm) and 10" (254 mm).

NBC (National Building Code) Requirement:

Vents in slope roofs 1 in 6 or greater shall be distributed so that approximately 50 per cent of the required vent area is located near the lower part of the roof and approximately 50 per cent of the required vent area is near the ridge.

Spacing: For any given roof, Thaler recommends a minimum 3" (76 mm) vent be located at each corner of the roof and a minimum of one vent in the middle of the roof. Venting efficiency is directly proportional to the number of vents employed e.g. 4 vents, each with 36 sq. in. (26 cm²) on a 300 sq. ft. (28 m²) roof is preferable to using 2 vents, each with a 72 sq. in. (54 cm²) of free venting area. Increasing the number of vents allows air to be drawn from the corners of the roof area thereby increasing overall venting efficiency while preventing the formation of condensation. Note: A minimum of two vents is required to vent any individual roof area.

Prominent Features: Urethane insulated liner prevents formation of condensation. Note: without insulation, condensate freezing in winter can thaw in spring and show up as leaks in ceiling. Also, in wintertime, moisture-laden warm air rising in the vent freezes on the underside of the hood rather than in the lower part of the vent and runs down the slope of the hood and out the vent holes to the exterior during periods of thaw.

RECOMMENDED USE

Suitable for all slope roofs for venting of plenum spaces. Primarily designed for built up roofing (BUR) and modified bitumen roofing, or single ply roofs providing the deck flange has been treated for proper weld with the single ply. e.g. PVC coated deck flange for PVC membrane or contact cement coated deck flange for EPDM membrane. Consult Thaler representative for other single plys. See Thaler GAV-4 Gravity Air Vents for larger capacity vents.

WARRANTY

20 year warranty against defects in materials and/or manufacture when installed in accordance with Thaler "Installation Instructions". Copy of Warranty Certificate available upon request.

MAINTENANCE

No maintenance required (maintenance free).

SPECIFICATION (Short Form)

Gravity air vents: Thaler [GAV-3A] [GAV-3C][GAV-3SS] standard 12" (305 mm) high, [3" (76 mm)][4" (102 mm)] diameter gravity air vent consisting of [.064" (1.6 mm) mill finish 1100-OT alloy aluminum] [.021 (0.53 mm) 16 oz. copper] [.018" (0.46 mm) Type 304 stainless steel] with integral deck flange, removable conical hood fitted to sleeve with three support brackets, insect screen and [bituminous painted deck flange] [PVC coated deck flange] [plain deck flange]; manufactured by Thaler Metal Industries, 1-800-387-7217 (Mississauga, Ontario, Canada) or 1-800-576-1200 (Niagara Falls, NY), installed as per manufacturer's written instructions. Provide 20 year warranty against defects in materials and/or manufacture.

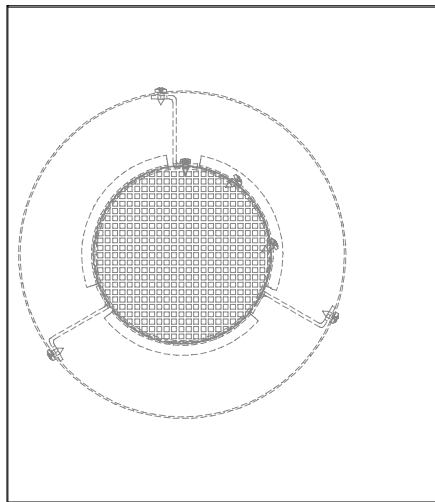
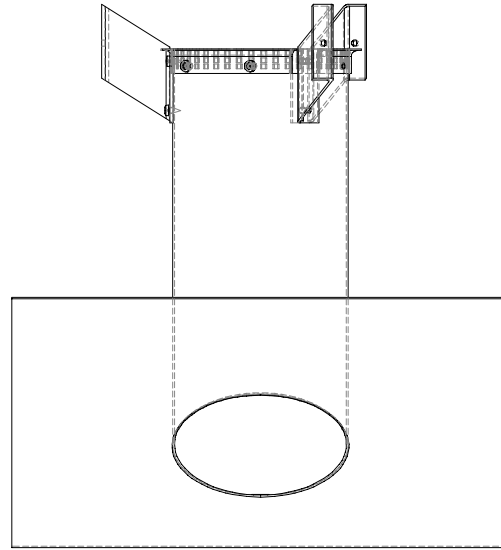
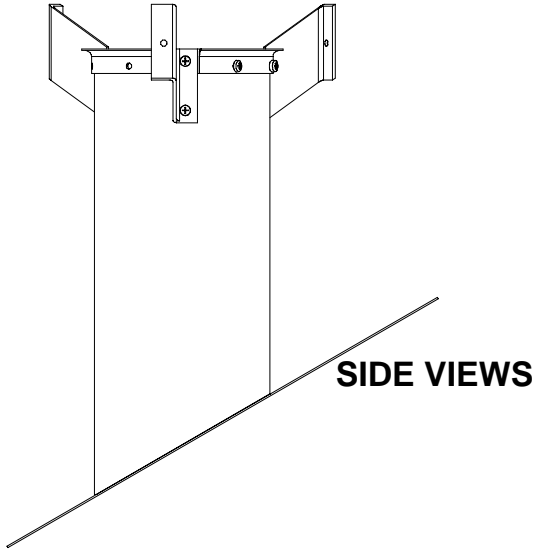
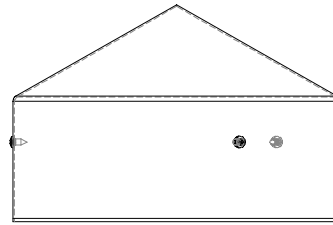
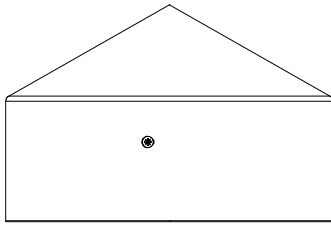

TOP VIEW

INSIDE DIAMETER (ID) VENT	FREE VENTING AREA (SQURE INCHES)
3" (76 mm)	7.07 (46 cm ²)
4" (102 mm)	12.6 (81 cm ²)
5" (127 mm)	19.63 (127 cm ²)
6" (152 mm)	28.27 (182 cm ²)
7" (178 mm)	38.48 (248 cm ²)
8" (203 mm)	50.27 (324 cm ²)
9" (229 mm)	63.62 (410 cm ²)
10" (254 mm)	78.54 (507 cm ²)

CALCULATING THE NUMBER OF GRAVITY AIR VENTS

144 Square inches (930 cm²) of free venting area is required to vent 300 square feet of roof area (1/300). A minimum of two vents are required to vent any individual roof area. Venting efficiency is increased in direct proportion to the number of vents used.

For example: Four vents each with 36 square inches (232 cm²) of free venting area on a 300 square foot (28 m²) roof is preferable to using two vents, each with 72 square inches (464 cm²) of free venting area. Increasing the number of vents, while maintain the required total amount of free venting area by decreasing the size of the individual vents allows air to drawn from the corners of the roof, thereby increasing overall venting efficiency, and avoiding condensation formation.

ROOF SPECIALTIES GAV-4A/-GAV-4C/GAV-4SS GRAVITY AIR VENTS (Large Size Vents-Slope Roofs)



A	B	C	D	Area Sq.Inches
12"DIA. (305mm)	24" (610mm)	14" (356mm)	6"-1/2" (165mm)	113.098 SQ.IN 730 (cm ²)
14"DIA. (356mm)	28" (711mm)	14" (356mm)	7" (178mm)	153.938 SQ.IN 993 (cm ²)
16"DIA. (406mm)	32" (813mm)	15" (381mm)	7-1/2" (191mm)	201.062 SQ.IN 1297 (cm ²)
18"DIA. (457mm)	36" (914mm)	16" (356mm)	8" (203mm)	254.470 SQ.IN 1641 (cm ²)
20"DIA. (508mm)	40" (1016mm)	18" (467mm)	8-3/4" (222mm)	314.160 SQ.IN 2026 (cm ²)

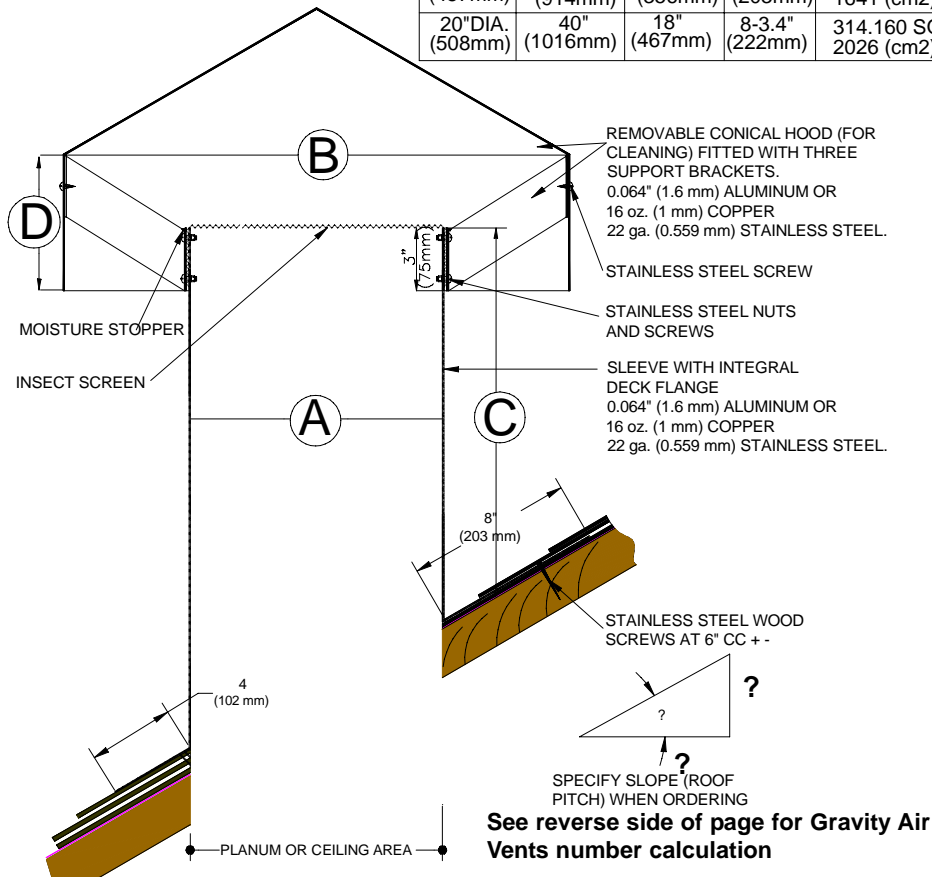

GAV-4A, GAV-4C, GAV-4SS GRAVITY AIR VENTS (Small Size Vents For Sloped Roofs)

INSTALLATION

"Installation Instructions" are provided with every Thaler product. Essentially, Thaler Gravity Air Vents are installed at recommended locations by first installing the roof membrane, then screwing the deck flange through to a wood blocking (by others) located under the membrane, and as follows:

BUR: Cut roof membrane back 1" (25 mm) from hole in deck before installing vent and fill space with plastic cement to prevent bitumen drippage at elevated roof temperatures. Set vent deck flange in layer of plastic cement and flash in with 3 overlapping layers of felt flashing.

ModBit: Cut roof membrane back 1" (25 mm) from hole in deck before installing vent and fill space with plastic cement to prevent bitumen drippage at elevated roof temperatures. Torch membrane until bitumen is fluid and set vent deck flange into fluid. Flash in flange with two overlapping layers of ModBit and seal with asphalt sealer.

Single Ply: Set vent deck flange in layer of membrane adhesive and extend single ply up vent sleeve to highest elevation possible and clamp membrane to sleeve. Note: for PVC membrane, specify PVC coated deck flange by adding suffix P to end of model number e.g. GAV-4A-P; weld roofing to deck flange using PVC torch. Note: for EPDM, coat deck flange on site with contact cement before torching membrane to deck flange.

Precautions: If coating deck flange with a bituminous paint on site, allow 24 hours for drying before applying roof membrane.

Ordering and Availability: Specify flashing material required by adding appropriate suffix to model number e.g. GAV-1A, for aluminum, etc. Available throughout North America. Contact Thaler for list of distributors and current cost information. Most products are readily available from stock.

DESCRIPTION

Thaler GAV-4 Gravity Air Vents for sloped roofs consist of a metal sleeve with integral deck flange, removable conical hood fitted to sleeve with a three support brackets, and insect screen. Available in aluminum (GAV-3A), copper (GAV-3C), or stainless steel (GAV-3SS).

Diameter: From 12" (305 mm) and 20" (508 mm).

NBC (National Building Code) Requirement:

Vents in slope roofs 1 in 6 or greater shall be distributed so that approximately 50 per cent of the required vent area is located near the lower part of the roof and approximately 50 per cent of the required vent area is near the ridge.

Spacing: For any given roof, Thaler recommends a minimum 3" (76 mm) vent be located at each corner of the roof and a minimum of one vent in the middle of the roof. Venting efficiency is directly proportional to the number of vents employed e.g. 4 vents, each with 36 sq. in. (26 cm²) on a 300 sq. ft. (28 m²) roof is preferable to using 2 vents, each with a 72 sq. in. (54 cm²) of free venting area. Increasing the number of vents allows air to be drawn from the corners of the roof area thereby increasing overall venting efficiency while preventing the formation of condensation. Note: A minimum of two vents is required to vent any individual roof area.

RECOMMENDED USE

Suitable for all slope roofs for venting of plenum spaces. Primarily designed for built up roofing (BUR) and modified bitumen roofing, or single ply roofs providing the deck flange has been treated for proper weld with the single ply. e.g. PVC coated deck flange for PVC membrane or contact cement coated deck flange for EPDM membrane. Consult Thaler representative for other single plys. See Thaler GAV-4 Gravity Air Vents for larger capacity vents.

WARRANTY

20 year warranty against defects in materials and/or manufacture when installed in accordance with Thaler "Installation Instructions". Copy of Warranty Certificate available upon request.

MAINTENANCE

No maintenance required (maintenance free).

SPECIFICATION (Short Form)

Gravity air vents: Thaler [GAV-4A][GAV-4C][GAV-4SS] [C high], [12" (305 mm)][14" (356 mm)] diameter gravity air vent consisting of [.064" (1.6 mm) mill finish 1100-OT alloy aluminum] [.021 (0.53 mm) 16 oz. copper] [.018" (0.46 mm) Type 304 stainless steel] with integral deck flange, removable conical hood fitted to sleeve with three support brackets, insect screen and [bituminous painted deck flange] [PVC coated deck flange] [plain deck flange]; manufactured by Thaler Metal Industries, 1-800-387-7217 (Mississauga, Ontario, Canada) or 1-800-576-1200 (Niagara Falls, NY), installed as per manufacturer's written instructions. Provide 20 year warranty against defects in materials and/or manufacture.

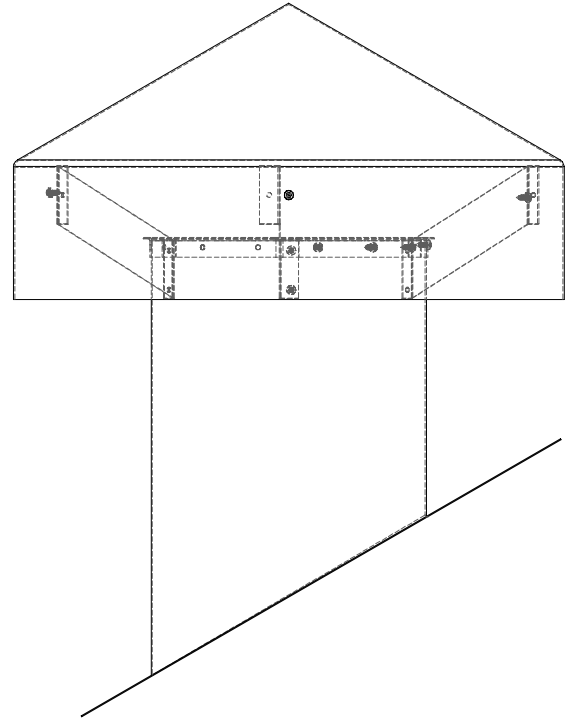
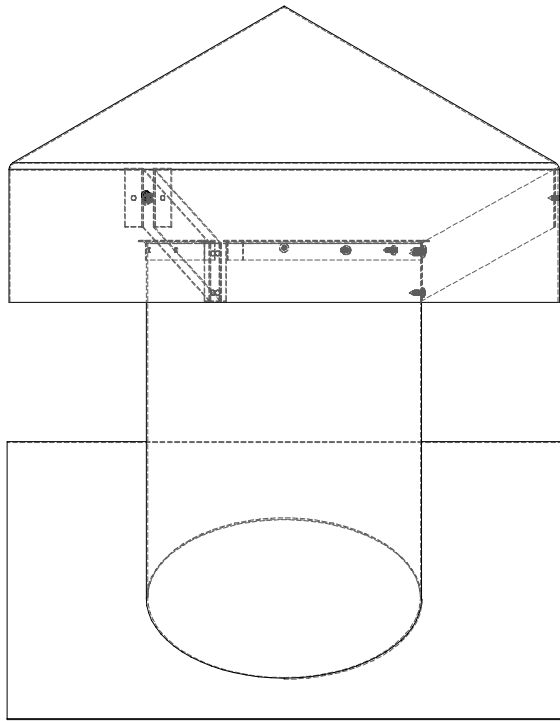

SIDE VIEWS

CALCULATING THE NUMBER OF GRAVITY AIR VENTS

144 Square inches (930 cm²) of free venting area is required to vent 300 square feet of roof area (1/300). A minimum of two vents are required to vent any individual roof area. Venting efficiency is increased in direct proportion to the number of vents used.

For example: Four vents each with 36 square inches (232 cm²) of free venting area on a 300 square foot (28 m²) roof is preferable to using two vents, each with 72 square inches (464 cm²) of free venting area. Increasing the number of vents, while maintain the required total amount of free venting area by decreasing the size of the individual vents allows air to be drawn from the corners of the roof, thereby increasing overall venting efficiency, and avoiding condensation formation.

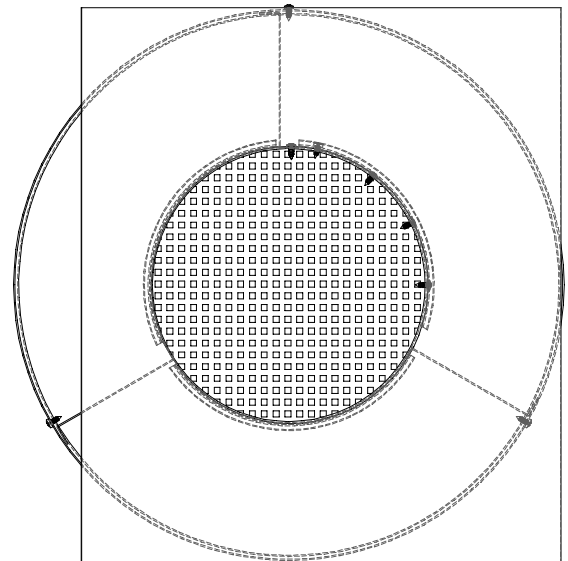

TOP VIEW